

Part Number: 08586-OC890

NOTE: Tundra and Sequoia use the same kit for the V2 System.

Conflicts

Do not install into vehicles without Factory Alarm Systems.

Recommended Sequence of Application

Item #	Accessory	

*Mandatory

Kit Contents

Item #	Quantity	Description
1	1	GBS ECU w/bracket attached

Hardware Bag Contents

Item #	Quantity	Description
1	1	M6 Flange Nut
2	1	GBS Microphone
3	2	V2 Window Label w/ red tag
4	2	V2 Window Label w/ red tag SPANISH
5	2	V5 Window Label (discard)
6	2	V5 Window Label SPANISH (discard)
7	1	V2 Owner's Manual
8	1	V5 Owner's Manual (discard)
9	1	Warranty Card (discard)







Additional Items For Installation (may be required)

Item #	Quantity	Description

Recommended Tools

Personal & Vehicle Protection	Notes
Safety Glasses	
Safety Gloves	(Optional)
Vehicle Protection	Blankets, Parts Boxes
Special Tools	Notes
Striker Tool (PPO only)	CAD-E IADS P/N ALL 02-016-01
Installation Tools	Notes
Flat Blade Screwdriver	Jewelers Screwdriver
Nylon Panel Removal Tool	e.g. Panel Pry Tool #1 Toyota SST # 00002-06001-01
Torque Wrench	52 in•lbf (5.9 N•m)
Tape	Clear
Masking Tape	
Socket	10mm, Extension
Special Chemicals	Notes
Cleaner	VDC approved cleaner
Glass Cleaner	Household Glass Cleaner

Legend

	STOP: Damage to the vehicle may occur. Do not proceed until process has been complied with.
	OPERATOR SAFETY: Use caution to avoid risk of injury.
	CAUTION: A process that must be carefully observed in order to reduce the risk of damage to the accessory/vehicle and to ensure a quality installation.
	TOOLS & EQUIPMENT: Used in Figures calls out the specific tools and equipment recommended for this process.
	REVISION MARK: This mark highlights a change in installation with respect to previous issue.
	SAFETY TORQUE: This mark indicates that torque is related to safety.

Care must be taken when installing this accessory to ensure damage does not occur to the vehicle. The installation of this accessory should follow approved guidelines to ensure a quality installation

These guidelines can be found in the "Accessory Installation Practices" document.

This document covers such items as:

- Vehicle Protection (use of covers and blankets, cleaning chemicals, etc.).
- Safety (eye protection, rechecking torque procedure, etc.).
- Vehicle Disassembly/Reassembly (panel removal, part storage, etc.).
- Electrical Component Disassembly/Reassembly (battery disconnection, connector removal, etc.).

Please see your Toyota dealer for a copy of this document

(A)	GBS ECU																		
(B)	GBS Microphone																		

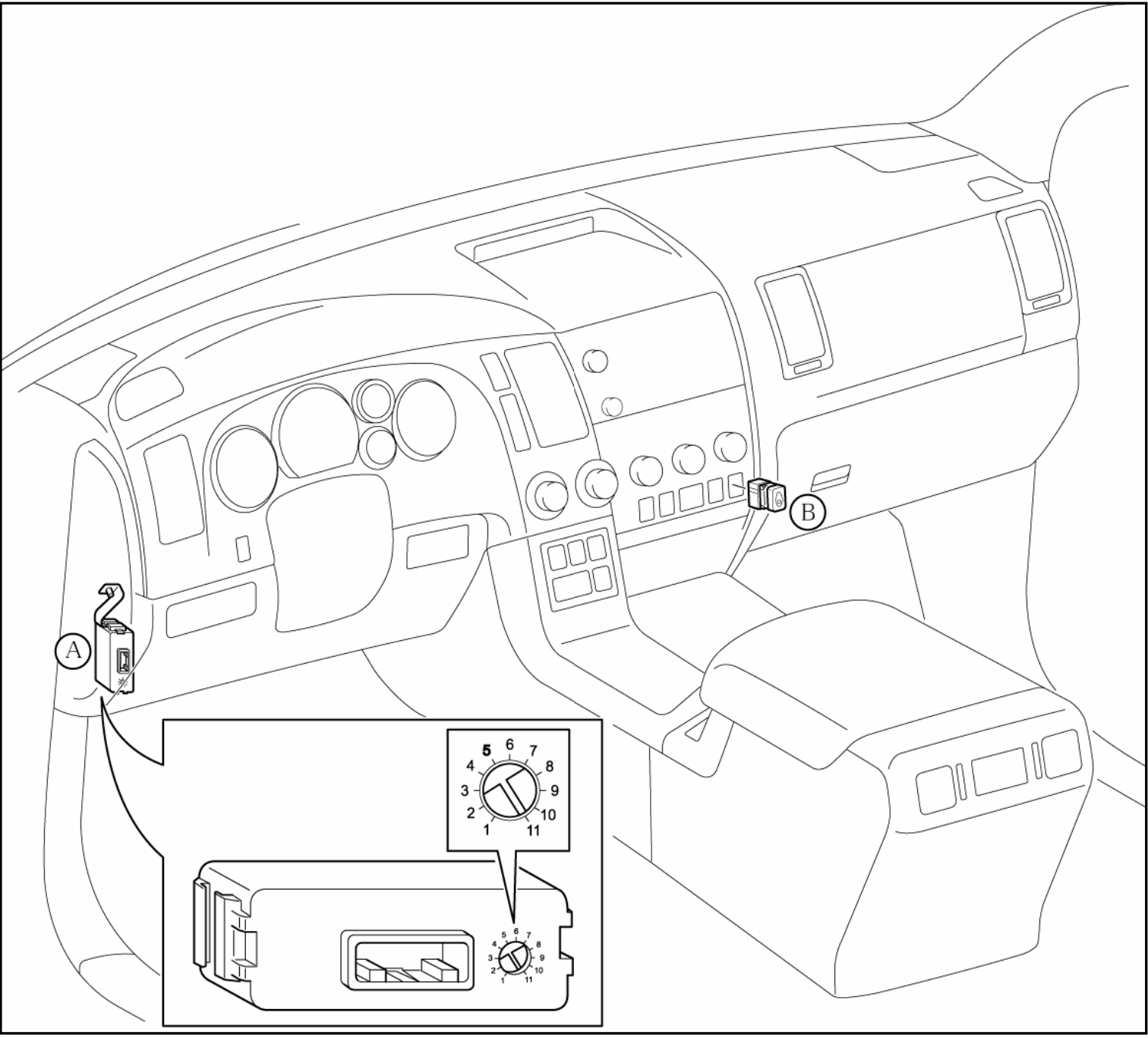

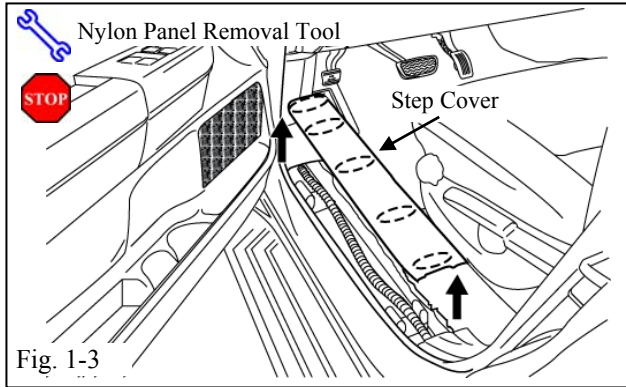

- (c) Remove the Driver's Step Cover. (Fig. 1-3)
 - (1) Protect the Vehicle Interior.

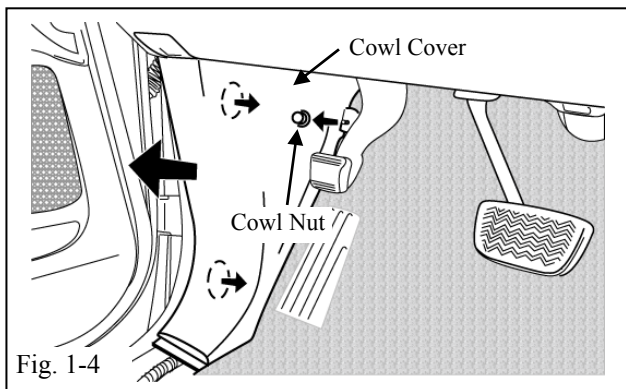

- (d) Remove the Driver's Cowl Cover. (Fig. 1-4)
 - (1) Remove 1 Cowl Nut.

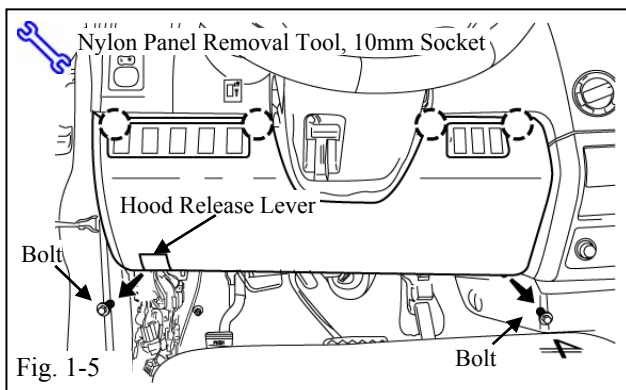

- (e) Dislodge the Lower Dash Cover. (Fig. 1-5)
 - (1) Remove 2 Bolts.
 - (2) Disconnect any connectors.

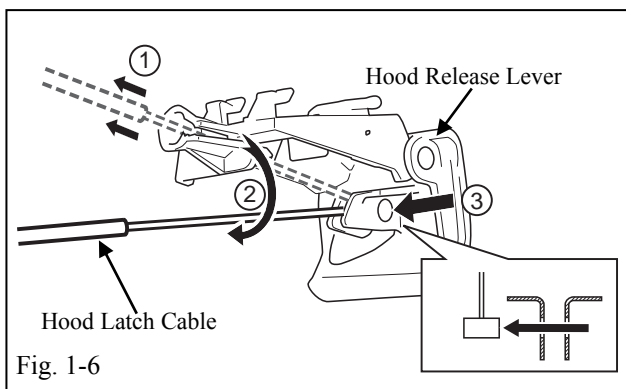

- (f) Remove the Hood Latch Cable from the Hood Latch Lever. (Fig. 1-6)
- (g) Remove the Lower Dash Cover.

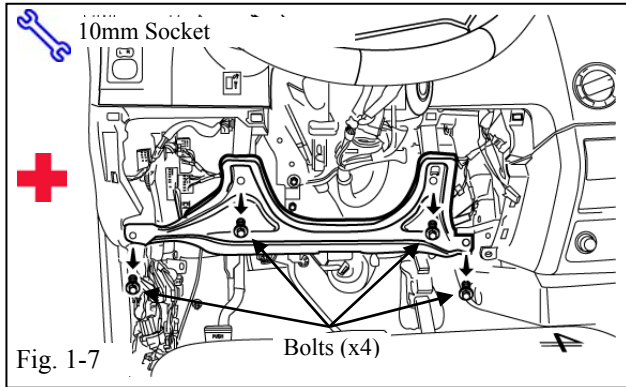

(h) Dislodge the Metal Substructure. (Fig. 1-7)

(1) Remove 4 Bolts.

+ CAUTION: Sharp metal edges.

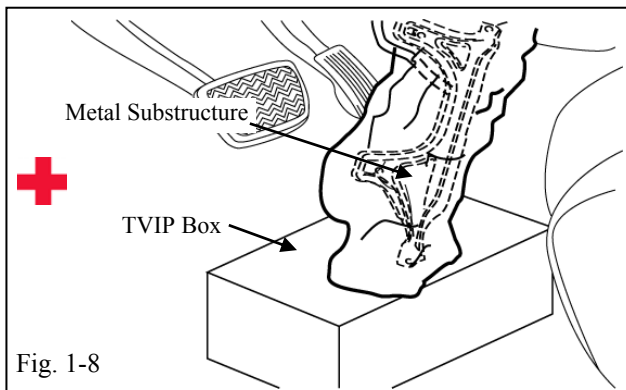

(i) Wrap the Metal Substructure in a Blanket and use the TVIP Kit Box to support it. (Fig. 1-8)

+ CAUTION: Sharp metal edges.

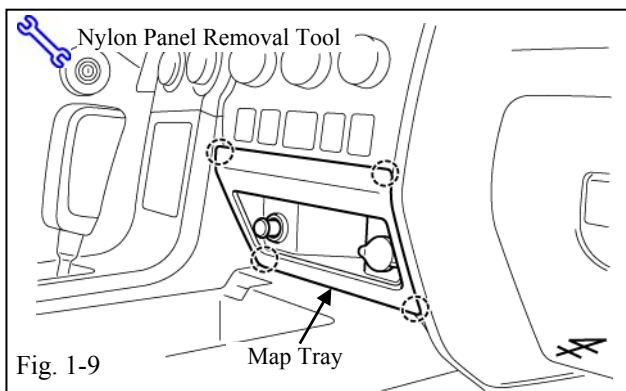

(j) Remove the small Map Tray below the Climate Control Console. (Fig. 1-9)

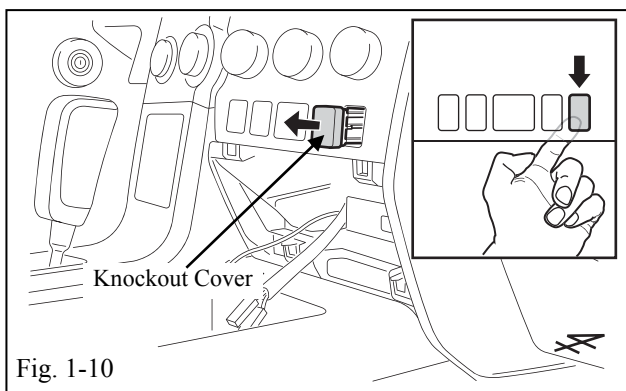

(k) Remove the indicated Knockout cover. (Fig. 1-10)

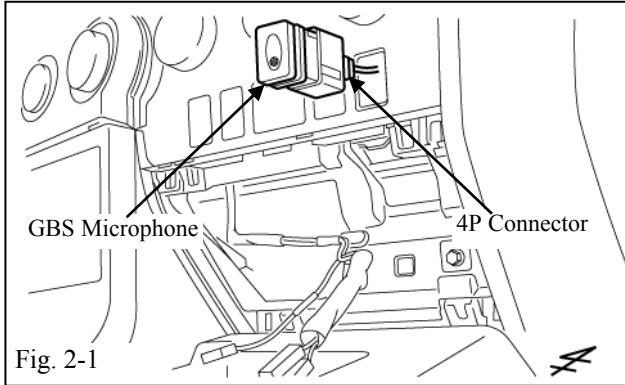

2. **GBS Microphone Installation.**

- (a) Feed the Vehicles White 4P Connector through the Climate Control Console and connect it to the GBS Microphone. (Fig. 2-1)

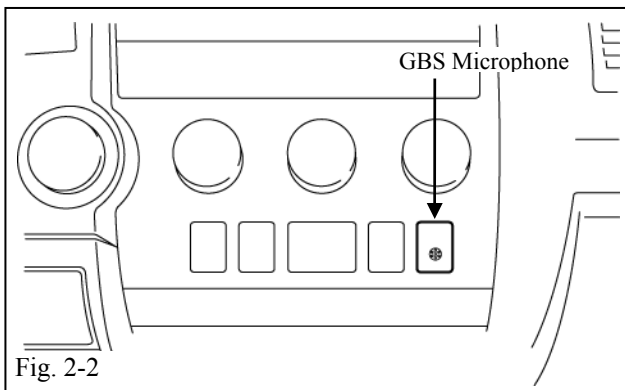

- (b) Insert the GBS Microphone into the Climate Control Console. (Fig. 2-2)

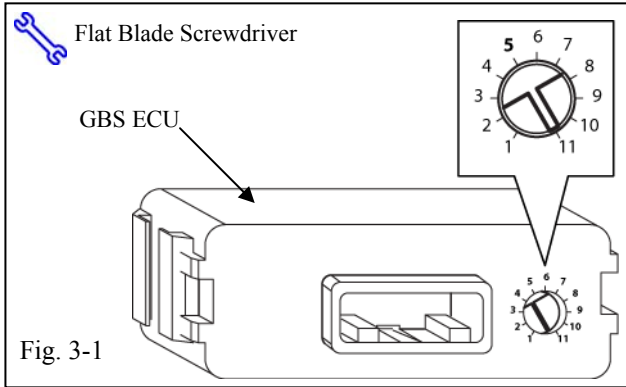

3. GBS ECU Preparation.

- (a) Verify that the GBS ECU's sensitivity is set to "5" position. (Fig. 3-1)
 - (1) Adjust if needed.

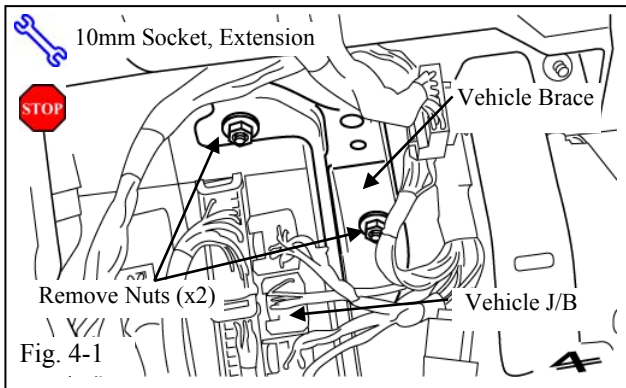

4. GBS ECU Installation.

- (a) Remove 2 Nuts from the Vehicle Brace near the Driver's Side J/B. (Fig. 4-1)
 - (1) Do not remove the Brace from the studs.
- (b) Pull the Brace away from the Vehicle Reinforcement. (Fig. 4-1)

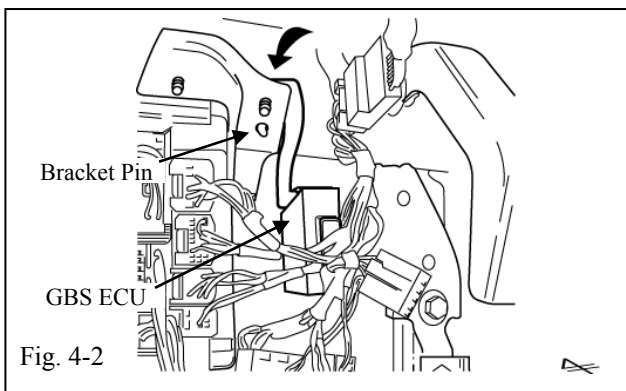

- (c) Install Bracket and GBS ECU. (Fig. 4-2)
 - (1) Make sure that the Bracket Pin seats properly.

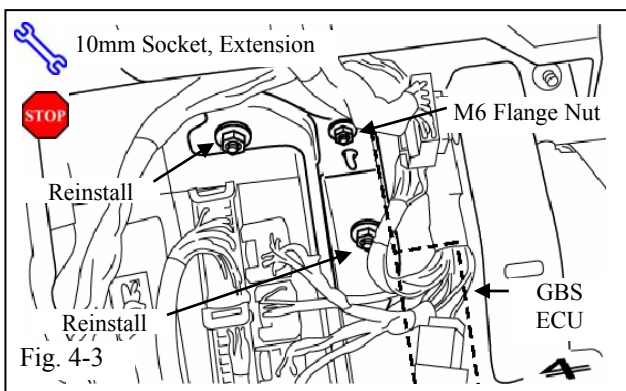

- (d) Use the M6 Flange Nut from the supplied kit to secure the ECU Bracket in place. (Fig. 4-3)
- (e) Re-secure the Vehicle Brace by reinstalling 2 Nuts. (Fig. 4-3)
 - (1) Verify that the Bracket is secure.

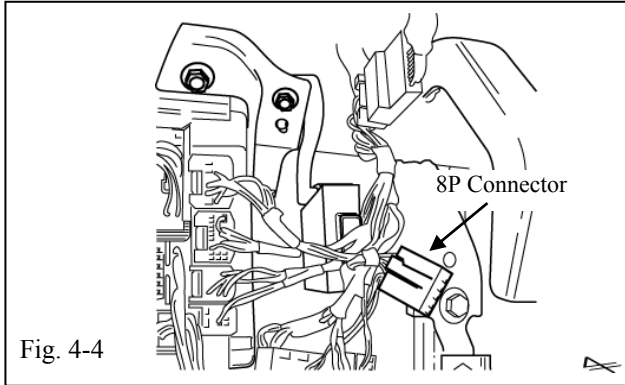

- (f) Locate the Vehicle's White 8P Connector near the Driver's Side J/B Area. (Fig. 4-4)
- (g) Remove the Tape securing the Connector.

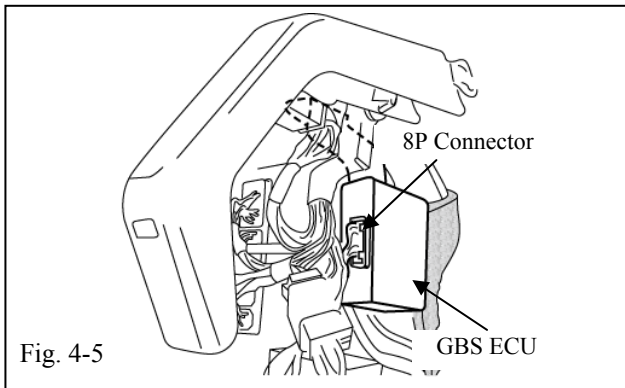

- (h) Connect the Vehicle Harness's White 8P Connector to the GBS ECU. (Fig. 4-5)

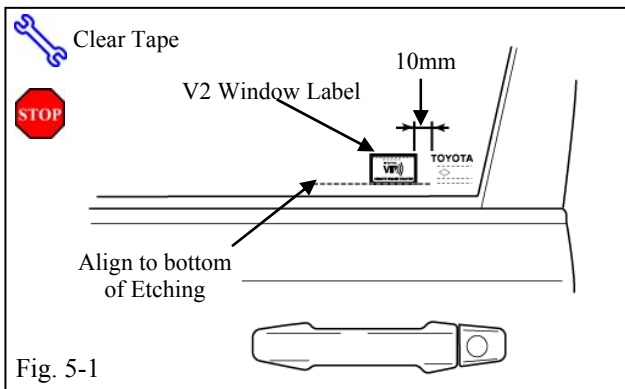

5. Window Label Installation.

- For US Vehicles use the English Labels and discard the Spanish Labels.
- For Mexico Vehicles use the Spanish Labels and discard the English Labels.

- (a) Using Household Glass Cleaner, clean the inside of the Front Door Windows. (Fig. 5-1)
- (b) Place the Warning Labels on the inside of the Front Door Windows as shown. (Fig. 5-1)

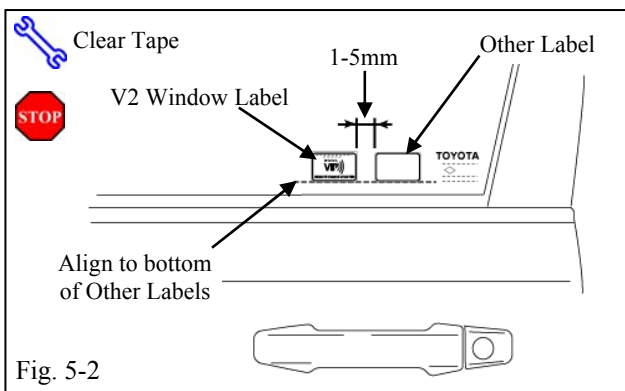

- (1) Use the Labels with Red Tags.
- (2) Use a piece of clean adhesive tape to lift the Labels off their protective backing.

STOP CAUTION: Do not touch the adhesive surface.

- (3) Line up the labels properly. Do not attempt to reposition the Labels once they are placed.

STOP NOTE: If Labels are being installed with other Window Labels align them as shown in Fig. 5-2.

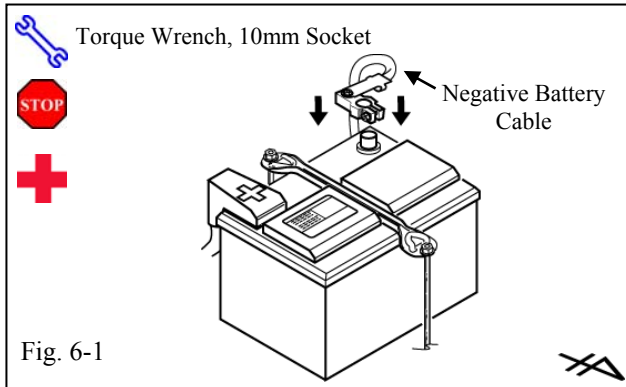

6. **Completing the Installation.**

- (a) Complete the reassembly of the Vehicle.
 - (1) Reconnect any disconnected Connectors.
 - (2) Verify the Panels fit together properly with no uneven gaps between them.
- (b) Position the Negative Battery Cable at the original factory position. (Fig. 6-1)
 - (1) Tighten the Nut to 52 in•lbf (5.9 N•m).



Torque: 52 in•lbf (5.9 N•m)



CAUTION: Do not touch the positive terminal.

- (c) Clean up and remove any trash.
- (d) Place the GBS Owner's Manual, sealed in the bag, in the Glove Box.
- (e) Discard RS3200Plus Owner's Manual, and Warranty Card.
- (f) Verify that the Short Pin is installed. (Fig. 6-2)
 - (1) Install if necessary.

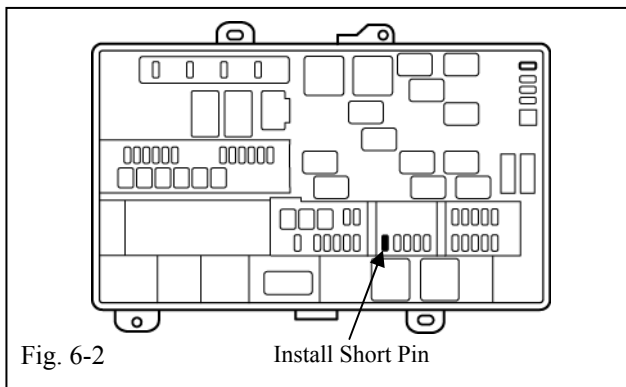

Accessory Function Checks

Roll up all windows, and exit the vehicle with the remote.

Perform		Look For
1	Lock the doors to start the system's arming process.	The turn signal lights flash once. All doors lock. The Security LED lights up.
2	Wait 30 seconds.	Security LED starts flashing; the system is now armed.

Perform the following check in a temperature controlled environment (50° - 90°F)

3	With the tip of a key, or Striker Tool pulled all the way out (PPO only), tap the center of the driver's door windows to trigger the alarm.	The horn sounds repeatedly. The headlights flash repeatedly. The turn signal lights flash repeatedly. The Security LED lights up.
4	Insert the key into the driver's door key cylinder and turn it toward the back of the vehicle to stop the alarm.	The horn stops sounding. All the lights stop flashing and/ or turn off. The Security LED lights up.

NOTE: If the alarm still does not trigger during the section test, increase the GBS sensitivity to the next setting and test again.

NOTE: If you do not disarm the system, the alarm will last 20 seconds. It is not necessary to check the alarm duration.

Vehicle Appearance Check

Perform		Look For
<input type="checkbox"/>	After accessory installation and removal of protective cover(s), perform a visual inspection of the vehicle.	Ensure no damage (including scuffs and scratches) was caused during the installation process. (For PPO installations, refer to TMS Accessory Quality Shipping Standard.)









Vehicle Function Checks

Function	Function
----------	----------

Enter the Vehicle

<input type="checkbox"/> Dome/Courtesy Lights	<input type="checkbox"/> Steering Wheel Column Adjusts Without Interference
<input type="checkbox"/> Horn	<input type="checkbox"/> Hood Latch Release

Start the Vehicle

<input type="checkbox"/> Starter	<input type="checkbox"/> Gauges
<input type="checkbox"/> Check Engine Light <i>If the warning light remains on, it may indicate a system malfunction.</i> 	<input type="checkbox"/> ABS Light (if equipped) <i>If the warning light remains on, it may indicate a system malfunction.</i> 
<input type="checkbox"/> Lamp Failure Sensor <i>If the warning light remains on, it may indicate a system malfunction.</i> 	<input type="checkbox"/> Track/Skid Control Light (if equipped) <i>If the warning light remains on, it may indicate a system malfunction.</i> 
<input type="checkbox"/> Seat Belt Warning Light <i>If the warning light remains on, it may indicate a system malfunction.</i> 	<input type="checkbox"/> Tire Pressure Monitoring System (TPMS) (if equipped) <i>Prior to TPMS activation and Pre-delivery Service (PDS) of the Vehicle the TPMS light will blink when IG is turned on.</i> <i>After TPMS activation and PDS of the Vehicle the TPMS light will illuminate for a few seconds and go off when IG is turned on.</i> 
<input type="checkbox"/> Air Bag Warning Light <i>If the warning light remains on, it may indicate a system malfunction.</i> 	
<input type="checkbox"/> Cruise Control Light (if equipped) 	

Using a Mirror or Assistant check the following.

<input type="checkbox"/> Trunk/Tailgate/Bed Lights (if equipped)	<input type="checkbox"/> Tail Lights
<input type="checkbox"/> Brake Lights	<input type="checkbox"/> Daytime Running Lights (if equipped)
<input type="checkbox"/> Backup Lights	<input type="checkbox"/> Marker Lights
<input type="checkbox"/> Clearance Sonar (if equipped)	

Stop the Engine, Place the Vehicle's IG in the ON position.

<input type="checkbox"/> Hazard Lights	<input type="checkbox"/> Turn Signal Lights
<input type="checkbox"/> Head Light	<input type="checkbox"/> Fog Lights (if equipped)
<input type="checkbox"/> High Beams	<input type="checkbox"/> Accessory Controls/Illumination (if equipped)
<input type="checkbox"/> Power Side Mirrors (if equipped)	<input type="checkbox"/> Convenience Memory Settings (if equipped)
<input type="checkbox"/> Power Sliding Door (if equipped)	<input type="checkbox"/> Rear Sunshade (if equipped)

Function		Function	
<input type="checkbox"/>	Front Wiper/Washer	<input type="checkbox"/>	Rear Wiper/Washer (if equipped)
<input type="checkbox"/>	Power Sun/Moon Roof (if equipped)	<input type="checkbox"/>	Rollover Side Curtain Air Bag Switch (RSCA) (if equipped)
<input type="checkbox"/>	Clock (if equipped)	<input type="checkbox"/>	Navigation System (if equipped)
<input type="checkbox"/>	Audio/Video (if equipped)	<input type="checkbox"/>	HVAC
<input type="checkbox"/>	Steering Wheel Audio Control (if equipped)	<input type="checkbox"/>	Rear Window Defogger (if equipped)
<input type="checkbox"/>	Front Windshield Defogger (if equipped)	<input type="checkbox"/>	Accessory Power Socket (if equipped)
<input type="checkbox"/>	Side Mirror Defogger (if equipped)	<input type="checkbox"/>	Heated/Vented Seats (if equipped)
<input type="checkbox"/>	Massage Seats (if equipped)		
<input type="checkbox"/>	Glovebox Light (if equipped)	<input type="checkbox"/>	Passenger Air Bag Switch (if equipped)
<input type="checkbox"/>	Power Locks (if equipped)	<input type="checkbox"/>	Power Windows (if equipped)
<input type="checkbox"/>	Power Seats (if equipped)	<input type="checkbox"/>	Key Sensor Buzzer

Remove the short pin after Function check.
 Check with your Port/Dealer to see if this step is necessary.

